

APEX ST SERIES ECONOMICAL AND EFFICIENT IN A LIGHT-WEIGHT PACKAGE

The ST Series Sprue Pickers have high performance, speed and flexibility in one exceptionally reliable package. The compact lightweight design permits quick, easy installation. Oil-less pneumatic drive system is virtually maintenance free, increasing reliability.

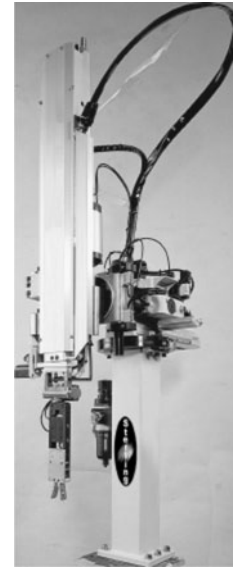

Features

- Performance, speed and flexibility in your choice of two exceptionally reliable packages
- Compact, lightweight design permits quick, easy installation
- Oilless pneumatic drive system is virtually maintenance-free, increasing reliability
- Programmable microprocessor controller includes an easy-to-operate, hand-held pendant
- B-90° wrist rotate for proper placement of sprue

Options

- The compact lightweight telescopic vertical arm (standard on SR-ST 750-950 models)
- Vertical motions ride on linear bearings which allow for lower profiles with increased speed and rigidity
- Venturi vacuum circuit with verification and adjustable vacuum tool
- Slowdown at part release (standard on telescoping 'T' units)
- Mold spray system with controller (excludes nozzles)
- Swing out home position for rack molds
- Non-SPI version
- Spanish version controller
- Tool-free adjustments



APEX ST SERIES

SPECIFICATIONS

Model	Vertical Stroke (mm/in)	IMM Range (tons)	Dry Cycle (sec)		Net Weight (kg)
			Take-Out	Overall	
ST550	550/21.7	60-150	0.7	3.7	40
ST-550T			0.5	3.5	49
ST-650	650/25.6	125-250	1.2	4.2	44
ST-650T			0.6	3.6	53
ST-750T	750/29.5	200-350	0.8	3.8	55
ST850T	850/33.5	300-450	1.0	4.0	57
ST-950T	950/37.4	400-700	1.2	4.2	59

T: Telescopic

Model	Gripper Height (mm/in)	Overall Height (mm/in)	Handle Height (mm/in)	Swing Centerline (mm/in)
	A	B	C	D
ST-550	180/7.1	1236/48.7	373/14.7	563/22.2
ST-550T		1094/43.1	403/15.9	594/23.4
ST-650	230/9.1	1393/54.8	423/16.7	613/24.1
ST-650T		1194/47	453/17.8	644/25.4
ST-750T	280/11	1294/50.9	503/19.8	694/27.3
ST850T	330/13	1394/54.9	553/21.8	744/29.3
ST-950T	380/15	1494/58.8	603/23.7	794/31.3

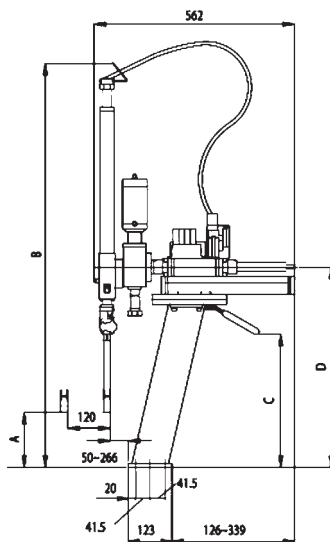

ST-550/650

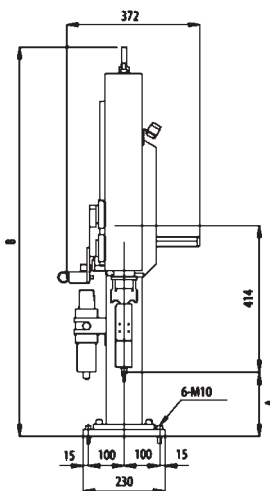

ST-XXXT

