

## BULK STORAGE SERIES EFFICIENT, HOMOGENEOUS BLEND OF DRY MATERIALS

Sterling Batch Mixers provide an efficient method of obtaining a homogeneous mix of most dry materials. Our mixers excel for industries including chemicals, plastics, metals, food, and drug. This proven line of mixers handle materials including pellets, flakes, granules, and powders, each mixed and ready to process. Various mix capacities are offered in addition to various loading/discharge capabilities. Accessories are also available to meet custom process needs.



### Features

- Heavy Duty Industrial Auger
- 12 Gauge Construction (varies by model)
- Manual or Automatic Timers
- NEMA 12 Controls
- One Piece Welded Construction
- 60° Hopper Section
- Slide Gate at Discharge
- Sidewall View Window
- Cover Adaption for Mounting
- Vacuum box with one 2" outlet (varies by model)
- Vacuum Receiver Lid (varies by model)
- Painted Warm Gray

### Options

- Various Materials of Construction
- Special Paint
- Lift Off Top and Auger Assembly for Cleanout (varies by model)
- Larger Diameter Mixing Auger (varies by model)
- Cutouts for Mounting Vacuum Receivers (varies by model)
- Stands for Gravity discharge
- Side loading chutes for additives (varies by model)
- Top loading chutes for box dumper loading (varies by model)
- Additional view windows
- Prox-lock out
- Inside service ladder (varies by model)
- Custom Extended legs for container fill (varies by model)
- Vacuum distribution box or auger discharge (varies by model)
- Custom bottom loading chutes for box dumper loading



# BULK STORAGE SERIES

## SPECIFICATIONS

Capacity, cu. ft.	Dia., in.	OAH, in.	Loading Height, in.	Hopper	Auger, in.	Motor	Footprint, in.
5	24	49	35	60°	3	110V, 1 ph, 1/3 HP	24
10	48	65	50	60°	9	480V, 3 ph, 2 HP	34
10	48	65	50	60°	9	240V, 3 ph, 2 HP	34
20	48	70	60	60°	6	480V, 3 ph, 2 HP	44
20	48	70	60	60°	6	240V, 3 ph, 2 HP	44
30	48	80	70	60°	6	480V, 3 ph, 2 HP	44
30	48	80	70	60°	6	240V, 3 ph, 2 HP	44
45	48	95	85	60°	6	480V, 3 ph, 3 HP	44
45	48	95	85	60°	6	240V, 3 ph, 3 HP	44
60	48	110	100	60°	6	480V, 3 ph, 3 HP	44
60	48	110	100	60°	6	240V, 3 ph, 3 HP	44
75	62	127	115	60°	12	480V, 3 ph, 7.5 HP	49
75	62	127	115	60°	12	240V, 3 ph, 7.5 HP	49
90	62	134	122	60°	12	480V, 3 ph, 7.5 HP	49
90	62	134	122	60°	12	240V, 3 ph, 7.5 HP	49
120	62	152	140	60°	12	480V, 3 ph, 7.5 HP	49
120	62	152	140	60°	12	240V, 3 ph, 7.5 HP	49

### DIMENSIONS

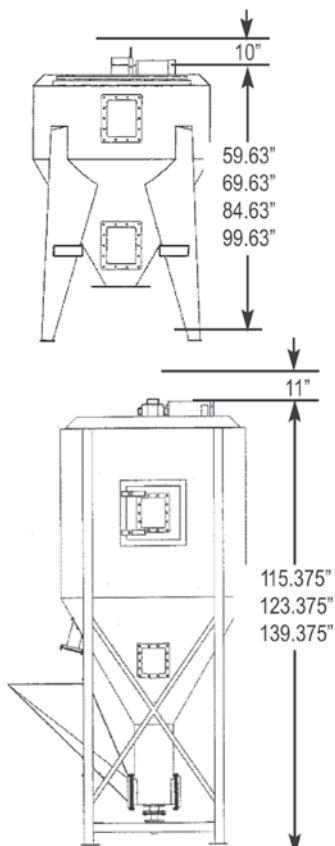

### STANDS FOR GRAVITY DISCHARGE

For use with batch mixers  
Consult Factory

