

BULK STORAGE SERIES **QUICK, AFFORDABLE SOLUTION FOR** **MATERIAL HANDLING NEEDS**

Sterling's full line of Container Dumpers removes material from containers and places it into your material handling system quickly and affordable. The line includes vertical lift and dump equipment, totally enclosed dust containment units, floor level and elevated dumpers.

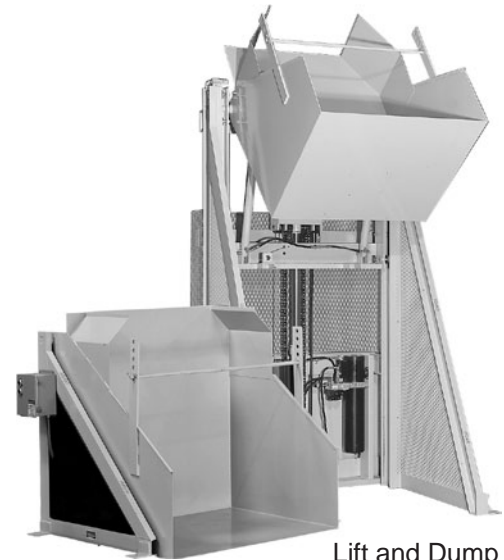

Rear Load Box Dumper

Lift and Dump

Features

- Lift and Rotation Capacity – 2500 lbs.
- Self Contained Power Units Electric/Hydraulic or Air/Hydraulic
- 135° Dump Rotation
- Adjustable Box Retainer Bar
- Bronze Bushing at Pivot Point
- 2" or 3" Hydraulic Cylinder
- Pinch Point Safety Guards
- 115 volt Control Panel – NEMA 12 Enclosures
- Safety Flow Control Valve
- Dump Heights – 4' to 20'
- Heavy Duty Frame and Bucket Construction
- Painted Warm Gray

Options

- Available in Various Materials of Construction
- Special Paint
- Large Lift Capacities
- Explosion Proof and Wash Down Electrics
- Adaption to Larger Containers
- Custom Enclosed Units for Dust Control

BULK STORAGE SERIES

SPECIFICATIONS

Type	Motor	Width, in.	Dump Height, in.
Rear load	3 phase, 480 V	48	48
Rear load	3 phase 240 V	48	48
Rear load	3 phase, 480 V	52	48
Rear load	3 phase 240 V	52	48
Rear load	3 phase, 480 V	48	58
Rear load	3 phase 240 V	48	58
Rear load	3 phase, 480 V	52	58
Rear load	3 phase 240 V	52	58
Rear load	1 phase, 120 V	48	48
Rear load	1 phase, 120 V	52	48
Rear load	1 phase, 120 V	48	58
Rear load	1 phase, 120 V	52	58
Rear load	Air drive motor	48	48
Rear load	Air drive motor	52	48
Rear load	Air drive motor	48	58
Rear load	Air drive motor	52	58
Side load, left dump	3 phase, 480 V	55	48
Side load, left dump	3 phase 240 V	55	48
Side load, right dump	3 phase, 480 V	55	48
Side load, right dump	3 phase 240 V	55	48
Side load, left dump	1 phase, 120 V	55	48
Side load, right dump	1 phase, 120 V	55	48
Side load	Air drive motor	55	48
Lift and seal rear load	3 phase, 240/480 V	48	48
Lift and seal rear load	3 phase, 240/480 V	52	48
Vertical lift and dump	3 phase, 480 V	52	up to 8 ft.
Vertical lift and dump	3 phase 240 V	52	up to 8 ft.
Vertical lift and dump	3 phase, 480 V	52	up to 10 ft.
Vertical lift and dump	3 phase 240 V	52	up to 10 ft.
Vertical lift and dump	3 phase, 480 V	52	up to 12 ft
Vertical lift and dump	3 phase 240 V	52	up to 12 ft
Portable	3 phase	c.f.	48
Portable	1 phase	c.f.	48

SUPPORT STANDS

Type	Width, in.	Height, in
Rear	48	12-48
Rear	48	49-60
Rear	52	12-48
Rear	52	49-60
Side	55	12-24
Side	55	25-36
Side	50	37-48
Side	50	49-60

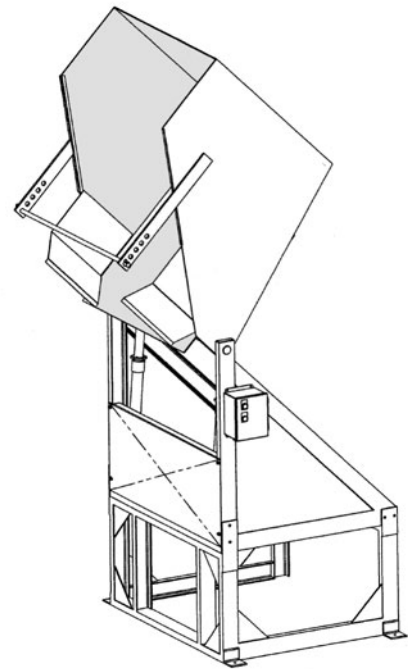

Box dumper with stand

SAFETY ENCLOSURE

Type
Use with box dumper
Use with lift and dump



BULK STORAGE SERIES

DIMENSIONS

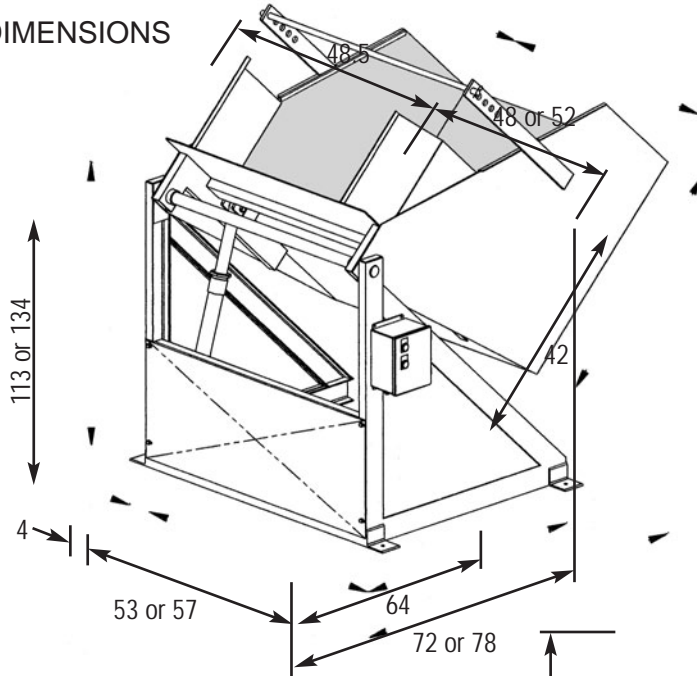

Box dumper, rear load

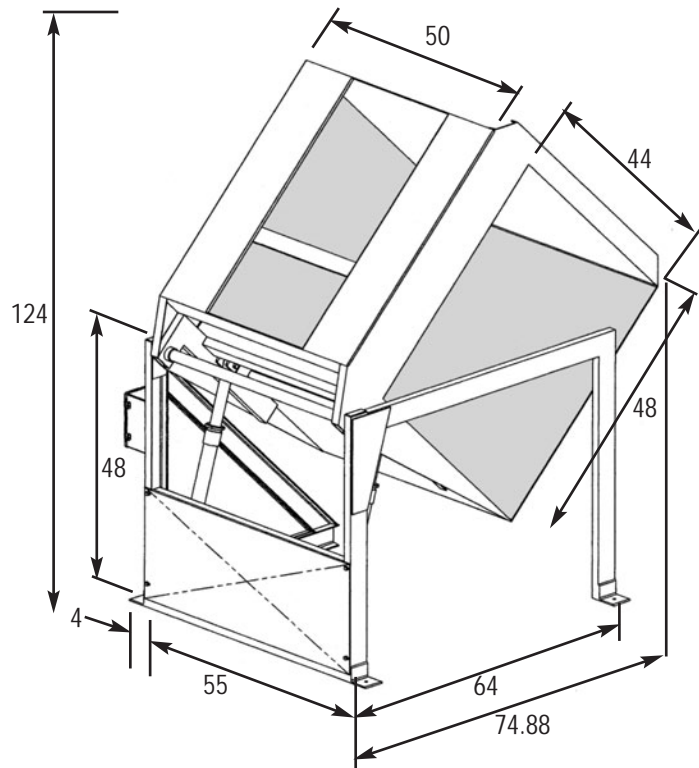

Box dumper, side load



BULK STORAGE SERIES

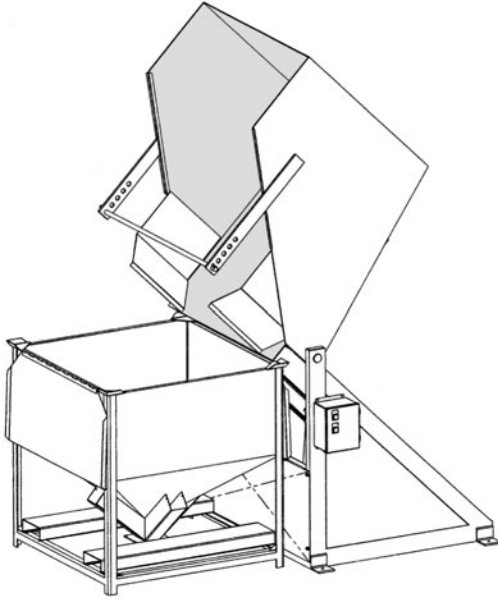

Box dumper with enclosed funnel

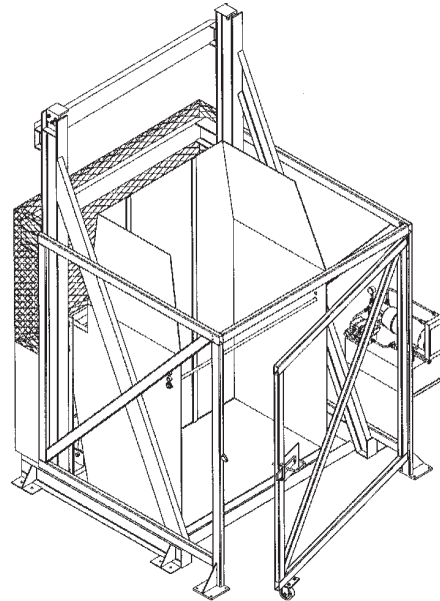

Lift and dump

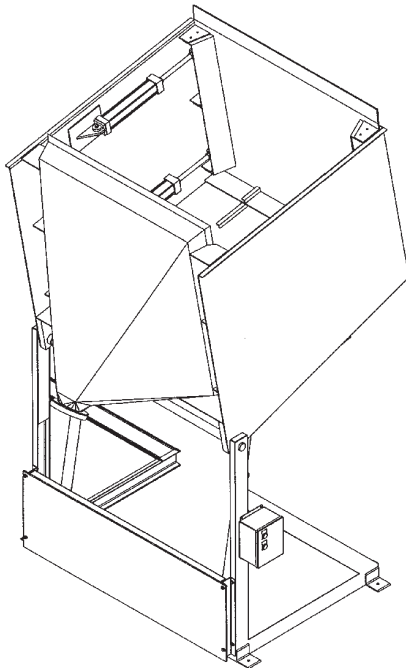

Lift and seal box dump

