

BULK STORAGE SERIES MOVE MATERIAL EASILY AND AFFORDABLY

Sterling Drum Dumpers remove material from drums and places it into your material handling system quickly and affordably. The line includes open chute drum dumpers, dust containment units, and vertical lift & dump units for extended dump heights. All equipment comes in various capacities and your choice of carbon, stainless, or aluminum material of construction.



Drum Dumper,
Dust Containment



Drum Dumper,
Open Chute

Features

- Lift and Rotation Capacity – 1200 lbs.
- Dump Rotation – 135° to a 45° Discharge
- Self Contained Hydraulic Power Unit, 2 HP
- Cone Discharge with 6" Butterfly Valve (Dust Containment Units Only)
- Adjustable Retainer Bar – 34" to 44" (Open Chute Only)
- Drum Top with FDA Approved Neoprene Drum Seal for Drums with 19" to 24" Diameter (Dust Containment Units Only)
- Floor Level Loading
- NEMA 12 Controls
- Dump Height 48"
- Heavy Duty Construction
- Painted Warm Gray

Options

- Available in Various Materials of Construction
- Special Paint
- Pneumatic Over Hydraulic Power Unit
- Pneumatic Iris Valves (Various Sizes and Materials)
- Pneumatic Butterfly Valve (Various Sizes and Materials of Construction)
- Caster Assemblies for Portability
- Explosion Proof Controls



BULK STORAGE SERIES

SPECIFICATIONS

Type	Motor	Description
Open chute	480/3/60	
Open chute	240/3/60	
Open chute	240/1/60	
Open chute	120/1/60	
Dust containment	230/460 V, 3 Phase, 2 HP	All stainless steel construction
Dust containment	230/460 V, 3 Phase, 2 HP	Stainless steel on contact
Dust containment	230/460 V, 3 Phase, 2 HP	Carbon steel construction

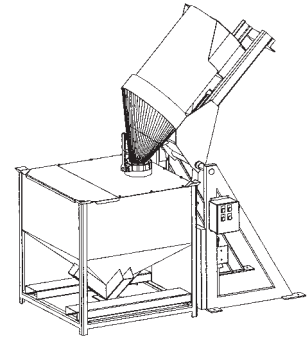

Lift and seal drum dumper

DIMENSIONS

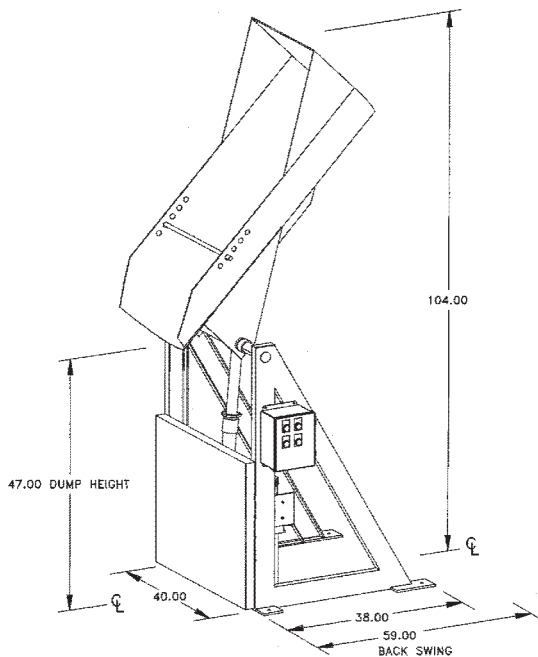

Drum dumper, open chute

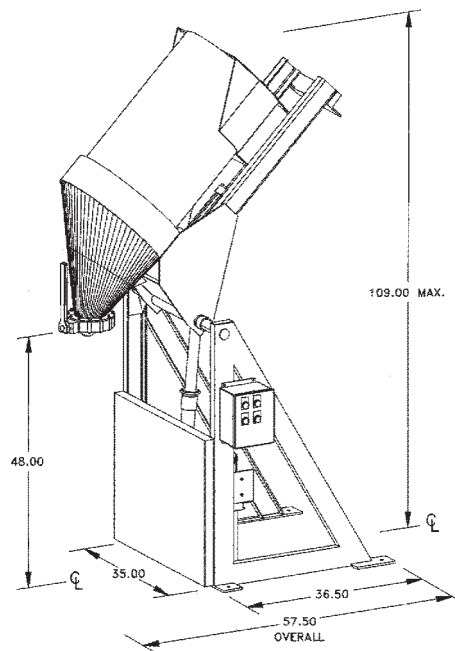

Drum dumper with dust containment

