

GH-F SERIES ELIMINATE COSTLY INACCURACIES AND OVER-FEEDING

The GH-F Series gravimetric feeder adds colorant or other free-flowing material to your process, based on a self-calibrating controller that makes recalibration unnecessary and eliminates the overfeeding that typically accompanies volumetric feeders.



Features

- Precision 0.02% span accurate weighing system
- Serial printer port
- Aluminum and mild steel contact surfaces
- DF-1 communications port (Ethernet optional)
- Field-mounted proximity switch for extruder speed pick-up
- Surge hopper with reload valve
- Square mounting flange for machine-mount
- Allen-Bradley remote control system with monochrome touch-screen
- 3" (76mm) OD discharge opening
- Extruder following circuit
- Hopper lid arranged for Sterling receivers and loaders
- 115/1/60 supply voltage

Options

- Customer-specified mounting flange
- Special voltage (transformer)
- Supply hopper lids cut for other vacuum receivers or loaders; cut-out pattern only¹

¹ Allow additional delivery lead times



GH-F SERIES

SPECIFICATIONS

Model	Max. feed rate, lbs./hr (kg/hr) ¹	Hopper capacity, lbs. (kg)	Auger size, in. (mm) ²	Shipping weight, lbs. (kg) ³	Crate dimensions, in. (cm) ³
GH-F 003	0.5-30 (0.22-13.6)	10 (4.5)	0.75 (19.1)	200 (91)	48 x 48 x 48 (122 x 122 x 122)
GH-F 009	5-90 (2.3-40.9)	10 (4.5)	1 (25.4)	200 (91)	48 x 48 x 48 (122 x 122 x 122)
GH-F 025	25-250 (11.4-113.5)	25 (11.4)	1-5/8 (41.3)	200 (91)	48 x 48 x 48 (122 x 122 x 122)
GH-F 040	40-400 (18.2-181.6)	25 (11.4)	2 (50.8)	200 (91)	48 x 48 x 48 (122 x 122 x 122)
GH-F 100	100-1000 (45.4-454)	50 (22.7)	3 (76.2)	200 (91)	48 x 48 x 48 (122 x 122 x 122)
GH-F 200	200-2000 (90.8-908)	50 (22.7)	4 (1.1.6)	200 (91)	48 x 48 x 48 (122 x 122 x 122)

¹ Rate is based on fifty (50) lbs./cu. ft. (800 kg/cu. m.) free-flowing pelletized additive. Actual rates may vary.

² GH-F Series models are available with various auger sizes that will affect throughput rate. Consult factory for guaranteed rates based upon individual applications. Material tests may be required.

³ Weights and dimensions listed are approximate; may vary based on exact feeder configuration, options, accessories, etc.

TYPICAL GH-F GRAVIMETRIC FEEDER

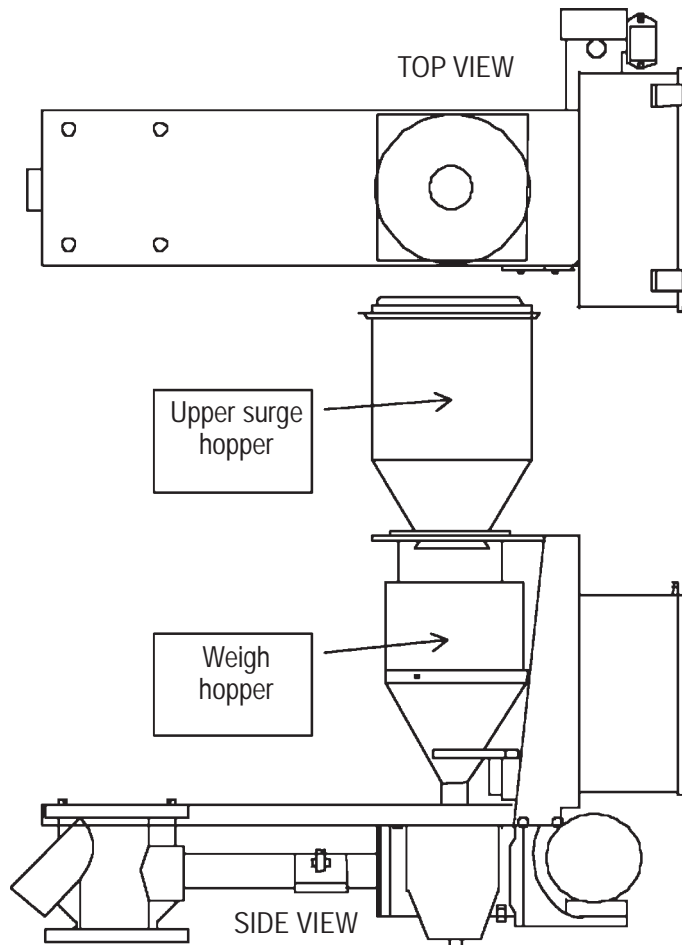

NOTES:

GH-F Series additive feeders are continuous loss-in-weight systems designed to work with continuous operation extrusion lines only. Any use other than with factory-approved extrusion applications is not recommended and may void any warranty or return and refund claims, implied and otherwise stated.

