

LP SERIES PORTABLE AND COMPACT FOR EVEN THE SMALLEST SPACES

The LP Series granulators are portable and low speed, with a feed chute, motor overload protection and visual alarm signal. Not only are they easy to maintain and quick to clean, but hinged construction allows easy accessibility to the cutting chamber. They also handle all sprues and rejects from injection molding machines.



Features

- Staggered horizontal rotor
- Smallest footprint squeezes into the tightest of spaces
- Quick and easy No Tools access – just open the front door
- Reversible (2) edge D2 bed comb
- Vacuum bin with 1.5" or 2" dia. take-offs available
- Locking swivel casters mounted on base rails
- TEFC 230/3/60 or 460/3/60 gear motor with 96 RPM rotor speed
- NEMA-12 electrical enclosure lighted START/ STOP pushbuttons
- 115/1/60 control voltage wired with electrical/ mechanical safety interlock
- Warranty – 1 year, parts and labor

Options

- Blade Setting Tool
- Blade Grinding Tool
- Level Indicator with Light
- Extension for Suction Tube

LP SERIES

SPECIFICATIONS

	LP43	LP86
Rotor	Staggered horizontal rotor	Staggered horizontal rotor
Rotor Knives	6 blades, D2 steel	15 blades, D2 steel, scissor-cut configuration
Bed Knives	2 HSS steel bed knives	2 HSS steel bed knives
Max. Material Size, in. (mm)	4 x 3 (100 x 80)	7.8 x 6.3 (220 x 160)
Max. Throughput, lbs./hr (kg/hr)	33 (15)	55 (25)
Connected Load, HP (kW)	2 (1.5)	3 (2.2)
Cutting Size, in. (mm)	3.9 (100)	9.8 (250)
Rotor Speed, rpm	96	107
Approx. Weight, lbs. (kg)	286 (130)	463 (210)
Working Envelope (LxW)	18.9" x 27.5"	19.4" x 34.3"

DIMENSIONS

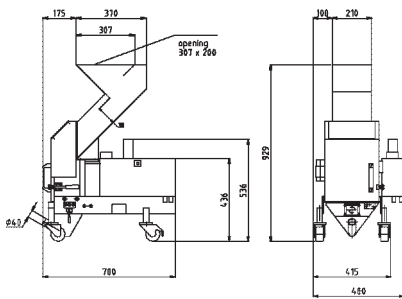

LP43

Standard Hand/Robot Feed Combination

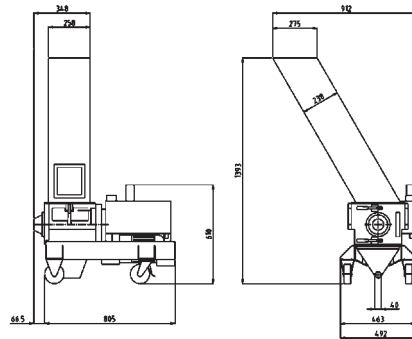

LP86

Standard Hand/Robot Feed Combination

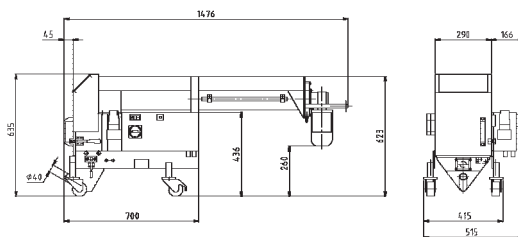

Spiral Auger Option

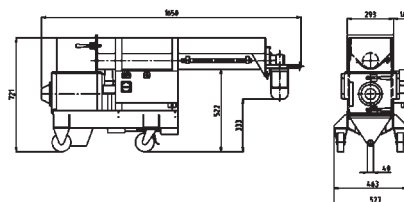

Spiral Auger Option

