

MICRO SERIES COMPACT SIZE PROVIDES BIG PERFORMANCE

All Micro Series water temperature control units have an operating leaving water temperature range of 32°F up to a maximum of 250°F (0°C to 121 °C).



Features

- Off-the-shelf 1/16th DIN microprocessor based PID controller
- Non-ferrous construction
- Easily removable panels for quick access to internal components
- Incoloy™ immersion heater with IEC contactors
- Pressure switch set at 16 psig
- NEMA 1 electrical enclosure
- 250 °F (121°C) maximum operating temperature
- Motor Circuit Protector
- Independent safety thermostat
- 1 year parts and labor warranty at the factory
- 3 year controller warranty

Options

- Casters; available in lieu of rubber feet
- Manual by-pass
- Pressure regulator/relief valve for water supply (shipped loose)
- Y-Strainer (shipped loose)
- Quick cool switch
- Auto system water purge (mold purge), shipped loose
- General fault audible/visual alarms
- Remote Start/stop
- Communications – RS232, RS485, RS485-SPI*
- Ten-foot power cord; no plug, shipped loose
- Rotary, thru-the-door disconnect switch
- UL/cUL-listed electrical subpanel
- Remote controller w/enclosure and 20 ft. cable, shipped loose
- Operating voltages: 208/3/60, 230/3/60, 400/3/50, 575/3/60
- Pressure gauges (Shipped loose, to be mounted on back of unit)

*RS485SPI requires a different controller



MICRO SERIES

SPECIFICATIONS

Model Number	Pump, HP (kW)	Flow, gpm (lpm)	Pressure, psig (bar)	Height, in. (mm)	Width, in. (mm)	Depth, in. (mm)	Ship. weight, lbs. (kg)
460 230							
Micro	0.5 (0.37)	15 (57)	20 (138)	17.5 (44)	9.5 (24)	23 (58)	110 (50)
	0.75 (0.56)	20 (76)	23 (159)	17.5 (44)	9.5 (24)	23 (58)	110 (50)

DIMENSIONS

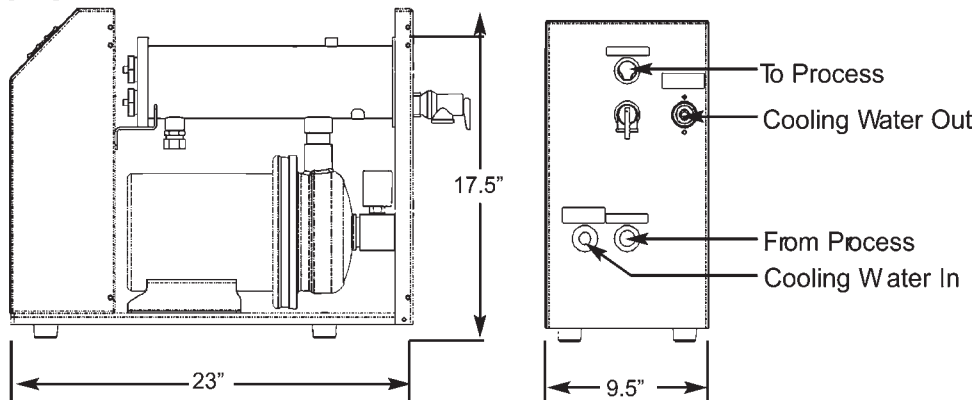

PART NUMBERING SCHEME

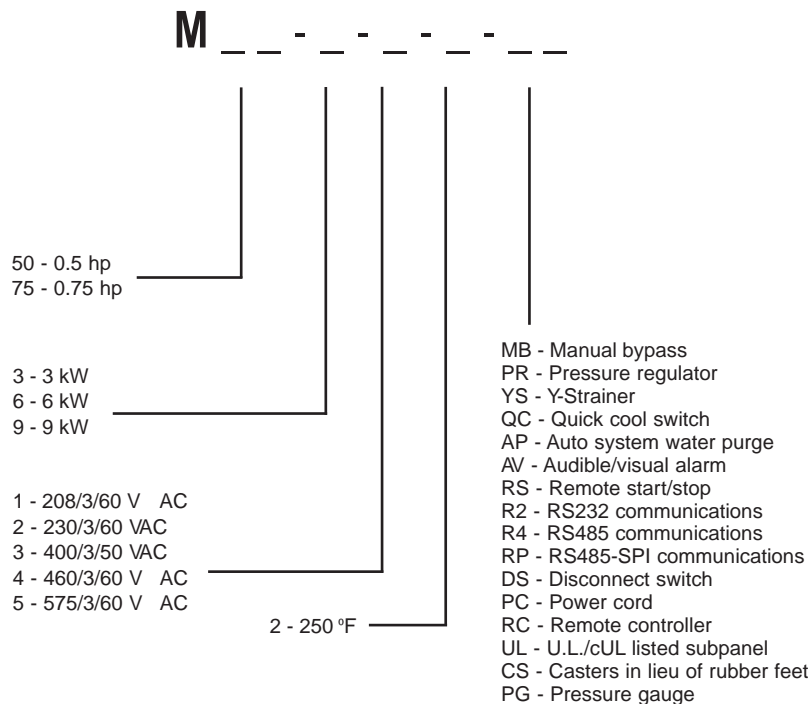

Example:
M75-9-4-2-AV-QC: Micro w/ 3/4 hp pump, 9 kW heater, 460 VAC, 250°F maximum operating temperature, Audible/Visual Alarm, and Quick Cool Switch

