

SCC 24/128 SERIES VERSITILITY AND CONTROL WITH MANIFOLD SHARING CAPABILITIES

Vacuum conveying has never been more simple or versatile than with Sterling's 24-pump, 128-station controller. The 24/128 controller features enhanced graphics and control of up to 24 vacuum conveying pumps, 128 loading stations, and 128 purge valves. The 24/128 controller utilizes a DeviceNet distributed I/O network. Standard features include an Allen-Bradley CompactLogix controller with a 10" color touch-screen operator interface.

The ArmorBlock distributed I/O modules and KwikLink flat wiring are compatible with DeviceNet communications. The network approach reduces installation costs by minimizing wire runs and allows for easy expansion and hot swapping of components, eliminating downtime.



Features

- Time fill loading
- Prioritized station loading
- Manifold line sharing
- Built-in system diagnostics
- Add new equipment and/or equipment options without shutting down the system
- Optimized for blender applications

Options

- Additional touch-screen operator interfaces for multi-location access within the plant
- Multiple vacuum pump and filter cleaning options
- Line purging capability
- Closed loop conveying
- Local station On/Off control
- Centralized remote proportioning valve control
- Blowback filter cleaning at the loading station
- Vacuum receiver positive discharge
- Volume-fill of vacuum receiver
- Low-level indication in supply hoppers
- Local alarm at each station
- Ethernet capabilities
- Supply power noise filter surge/suppressor
- Granulator unloading



SCC 24/128 SERIES

SCC 24/128 CONTROLLER

The sample control screens below show how versatile this powerful control platform is. Easy-to-follow graphical touch screens navigate you through total control of this central vacuum system controller.

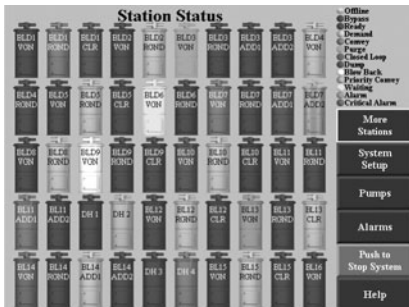

Naming of loading stations, pumps, purge valves and material sources

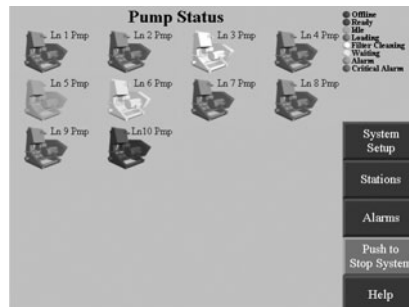

Pump status

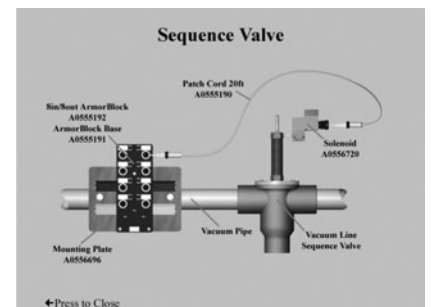

Built-in diagnostics, operating instructions and installation instructions

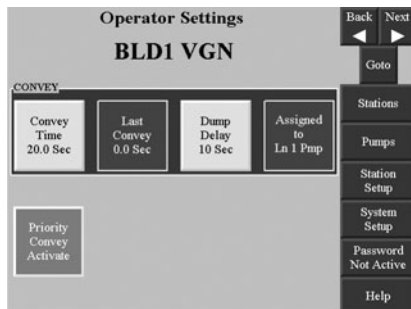

Operator Screen

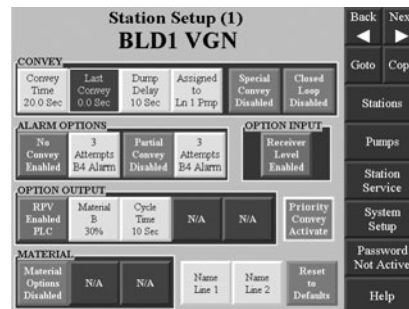

Set-up Screen

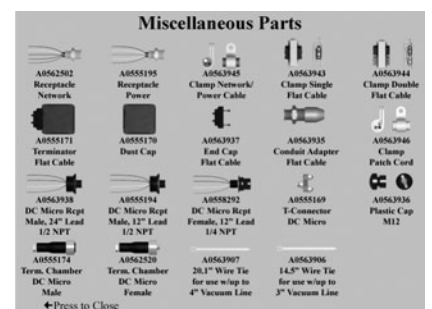

Spare Parts Screen