

**SFC-225/1000 SERIES
LOW MAINTENANCE FILTER
REDUCES MAINTENANCE TIME**

Every Sterling vacuum conveying system uses a remote central filter chamber to eliminate onthemachine filter maintenance as well as to protect the vacuum pump from damage due to dust or particle ingestion. For use with any SPD pump, the SFC cartridge style filter chamber features a two-stage dust collector that incorporates a cyclonic vortex separation chamber with a large-capacity cartridge filter element to produce a highly efficient, low-maintenance filter. The FC Series bag-style filter chambers are used with our SPDB power units with patented PulseJet Blowback for filter cleaning.

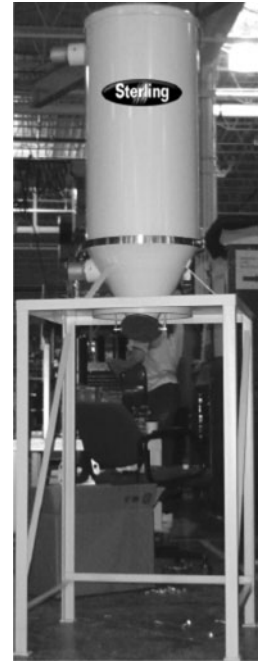
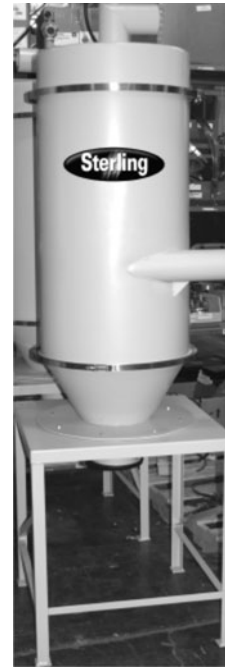

Features

SFC Cartridge Style Filter Chambers:

- Mild steel construction
- Two stage cyclone/cartridge filter design
- 29" high floor stand for drum discharge
- Reverse pulse filter element
- Flapper dump valve and filter shroud

FC Bag Style Filter Chambers:

- Mild steel construction
- 12 oz. glazed polyester felt bags
- Flapper dump valve with floor stand and dust shroud
- 45" floor stand with 38" clearance

Options

SFC Series:

- 45" floor stand, 38" clearance
- ½" compressed air solenoid for blowback (less controls)
- ½" compressed air solenoid for blowback with stand-alone control assembly
- Removable dust can on 29" floor stand

FC Series:

- Floor mount configuration
- Floor stand with manual dump valve
- Acrylic filter media
- Gore-Tex® filter media
- Enclosed floor stand
- Spare filter bag rack with polyester bags
- Manual dump configuration



SFC-225/1000 SERIES

SPECIFICATIONS

Model	Filter area, sq. ft. (sq. cm.)	Power unit, HP (kW)	Line size, in. dia. OD	Length, in. (cm)	Height, in. (cm)	Width, in. (cm)	Ship. weight lbs. (kg)
SFC225	35 (225.8)	5, 7.5, 10, 15 (3.7, 5.6, 7.5, 11.2)	2, 2.5, 3, 3, 3.5 (3 Sch. 5)	20 (51)	73 (186)	20 (51)	160 (73)
SFC1000	55 (354.9)	15, 20, 25, 30, 40, 50 (11.2, 14.9, 18.7, 22.4, 29.8, 37.3)	3.5 (3 Sch. 5), 4, 4.5 (4 Sch. 10), 5, 5 Sch. 10, 6 Sch. 10	26 (66)	90 (229)	26 (66)	200 (91)

Model	Filter area, sq. ft. (sq. cm.)	Power unit, HP (kW)	Line size, in. dia. OD	Length, in. (cm)	Height, in. (cm)	Width, in. (cm)	Ship. weight lbs. (kg)
FC15	15 (96.8)	5, 7.5, 10 (3.7, 5.6, 7.5)	2, 2.5, 3	28 (71)	28 (71)	62 (158)	120 (44)
FC30	30 (193.6)	10, 15 (7.5, 11.2)	3, 3.5 (3 Sch. 5)	28 (71)	28 (71)	89 (226)	160 (53)
FC55	55 (354.9)	20, 25, 30 (14.9, 18.7, 22.4)	4, 4.5 (4 Sch. 10), 5, 5 Sch. 10	28 (71)	28 (71)	101 (257)	200 (84)

DIMENSIONS

Model	A, in. (cm)	B, in. (cm)	C, in. (cm)	D, in. (cm)	E, in. (cm)
SFC225	20 (51)	62.88 (160)	45.25 (115)	17.50 (45)	29 (74)
SFC1000	28 (71)	78.88 (200)	60.88 (155)	25.50 (65)	29 (74)

SFC Cartridge-Style Vortex Filter Chambers

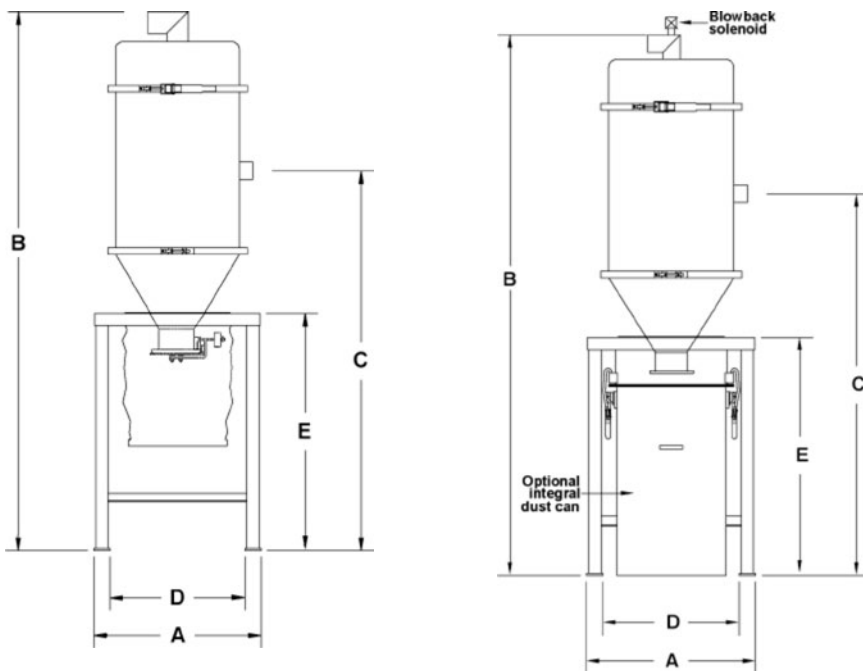

SFC-225/1000 SERIES

SPECIFICATIONS

Model	A, in. (mm)	B, in. (mm)	C, in. (mm)	D, in. (mm)		E, in. (mm)
FC-15	56 5/16 (1430)	15 1/2 (394)	42 (1067)	45 (1143)	20 (508)	28 (711)
FC-30	80 5/16 (2040)	15 1/2 (394)	66 (1676)	45 (1143)	20 (508)	28 (711)
FC-55	83 (2108)	20 (508)	76 (1930)	50 (1270)	26 (660)	35 (889)

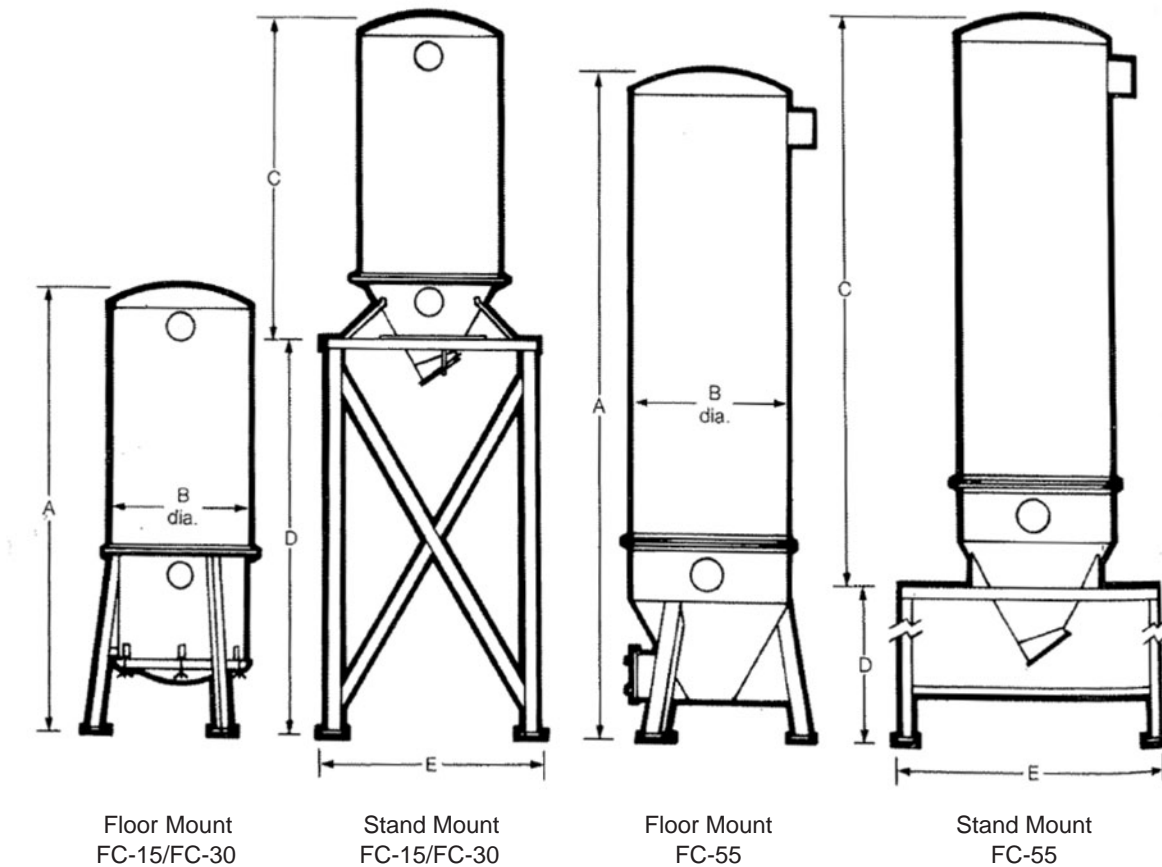



SFC-225/1000 SERIES

NOTES:

