

SVL SERIES

SVL SERIES COMPRESSED AIR LOADERS

Sterling's compact SVL loaders are designed to provide trouble-free conveying using compressed air. These highly efficient, self-contained loaders use compressed air and use an efficient venturi to draw material from drums, bins or gaylords.

The material is drawn through the venturi under vacuum and then conveys into the receiver using the shop compressed air. The material is separated from the air stream and is deposited into the bin or process machine. An efficient filtering system is used to capture material fines before air is exhausted into the plant. A simple control assembly is easy to operate and makes this loader a good choice for many single loading material conveying applications. Choose the configuration that is correct for your application.



SVL-A and SVL-B Series Standard Features

- Receiving hopper
- Standard flange with quick release fasteners
- Control assembly with low power consumption solenoid – 115/1/50-60 Hz
- Air filter/regulator combination with pressure gauge
- Capacitive sensor for material demand with 16.4 foot (5 meter) quick disconnect cable to control
- Venturi/wand assembly with quick connect air line fittings
- 3/8" poly hose air line – 10 ft.
- 1-1/4" standard vinyl flexible hose – 10 ft.
- Two hose clamps for 1-1/4" vinyl flex hose

SVL-C Series Standard Features

- Second venturi/wand assembly with quick connect air line fittings
- 1-1/4" O.D. wye-tube with coupler to attach to material inlet on receiving hopper
- Additional 3/8" poly hose air line – 10 ft.
- Additional 1-1/4" standard vinyl flexible hose – 10 ft.
- Additional Two hose clamps for 1-1/4" vinyl flex hose
- Control assembly set up for two venturi assemblies including two additional regulators with pressure gauges

SVL-D Series Standard Features

- Mobile drum stand with filtered drum cover
- Control assembly with low power consumption solenoid – 115/1/50-60Hz
- Capacitive sensor for material demand with 16.4 ft (5 meter) quick disconnect cable to control venturi/wand assembly with quick connect air fittings
- 1-1/4" standard vinyl flexible hose -10 ft.
- Two hose clamps for 1-1/4" vinyl flex hose
- 3/8" poly hose air line - 10 ft.

Options

- 230/1/50-60 voltage
- Universal adapter for grinder take-off attachment to fit up to 2" O.D. material line connection (slips over existing tube stub)
- Dust bag kit with tube in lieu of standard filter for dusty regrinds (not available for SVL-A loaders)



SVL SERIES

SPECIFICATIONS

Model	Maximum Throughput, lbs./hr (kg/hr)	Shipping Weight ¹ , lbs. (kg)	Operating Voltage	Noise Level, dbA	Compressed Air Supply, PSI (bar)	Compressed Air Consumption, scfm (psig)	Vacuum Performance, H2O (kPa)	Typical Comp. Air Consumption	Max. Product Temp., F° (C°)
SVL-A	475 (215)	16.6-20.6 (7.5-9.3)	115/1/50-60	< 75	70-90 (5-6)	25.9 (280) (Based on 100% continuous use)	-42" (-11)	8-10 scfm @ 80 psig based on 30% duty cycle for intermittent use	176 (80)
SVL-B		19.8-23.8 (9.0-10.8)							
SVL-C		29.6-33.6 (13.4-15.2)							
SVL-D		125.0 (56.7)							

¹ All weights include 10 lbs. for packing materials

MODEL NAMING MATRIX

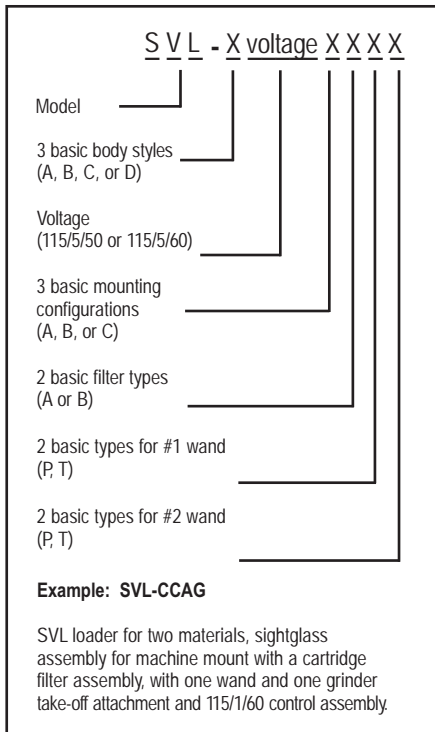

MODEL DESCRIPTION

SVL-A
The SVL-A is a single inlet venturi loader used to convey clean, pelletized material into a process. Price includes one pick-up material probe and single inlet control assembly. 115VAC.

SVL-B
The SVL-B is a single inlet venturi loader used to convey clean pellets or regrind material into a process. Price includes one pick-up device and single inlet control assembly. 115 VAC.

SVL-C
The SVL-C is a single inlet venturi loader with a special wye tube attachment that allows conveying of two materials (usually a virgin and regrind material) into a process. Price includes two pick-up devices and dual inlet control assembly. 115 VAC.

SVL-D
The SVL-D is a mobile stand with a single inlet conveying pellets or regrind to fill material drums. Price includes drum stand, one pick-up device, filtered drum cover and single inlet control assembly.

Body Type: (1st position of model number)
 A: Single inlet for clean pellets ONLY
 B: Single inlet for pellets or regrind
 C: Single inlet tank with WYE tube inlet two materials
 D: Drum fill station with one inlet for pellets or regrind

Voltage: (2nd position of model number)
 115/1/60: 115/1/60 VAC Control Assembly
 220/1/50: 220/1/50 VAC Control Assembly

Mounting: (3rd position of model number)
 A: Direct Mount (Less Flange Options - Standard)
 B: Bin Mount flange adapter (with SRC 02-16 bolt pattern)
 C: Sight glass assembly for machine mount

Filter: (4th position of model number)
 A: Cartridge Filter for pellets and clean regrind
 B: Dust bag kit with tube in lieu of standard filter for dusty regrinds (not available on SVL-A model)

Wand Selection: (5th and 6th positions of model number)
 P: Pickup
 T: Takeoff



SVL SERIES

SVL-A SPECIFICATIONS - ONE MATERIAL CONVEYING (CLEAN PELLETS ONLY)

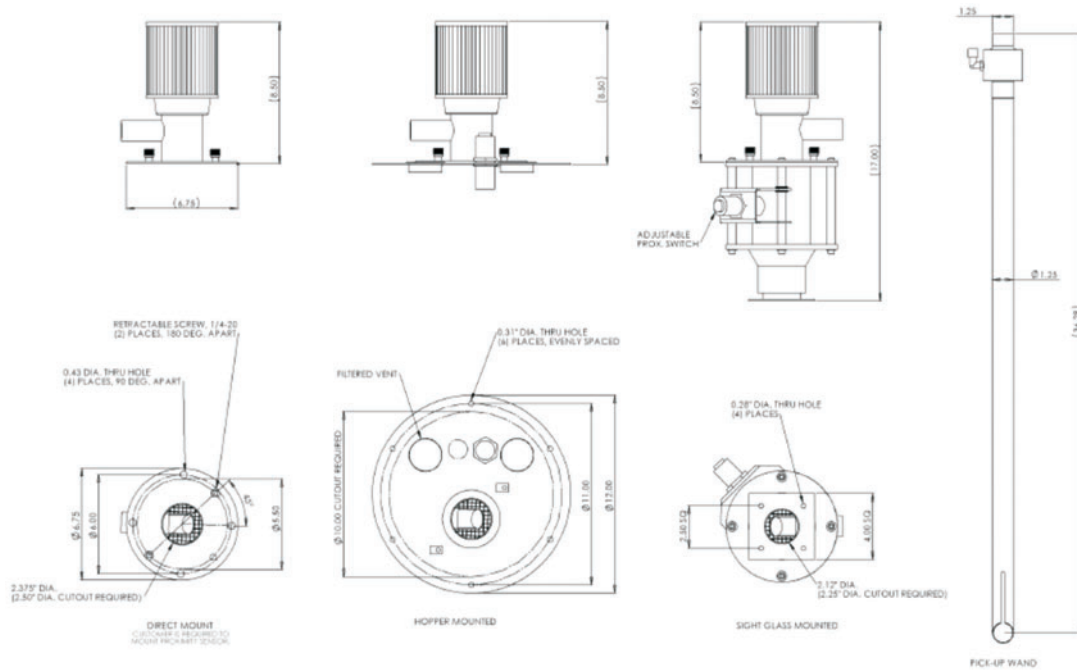

SVL-B SPECIFICATIONS - ONE MATERIAL CONVEYING (PELLETS OR CLEAN REGRIND)

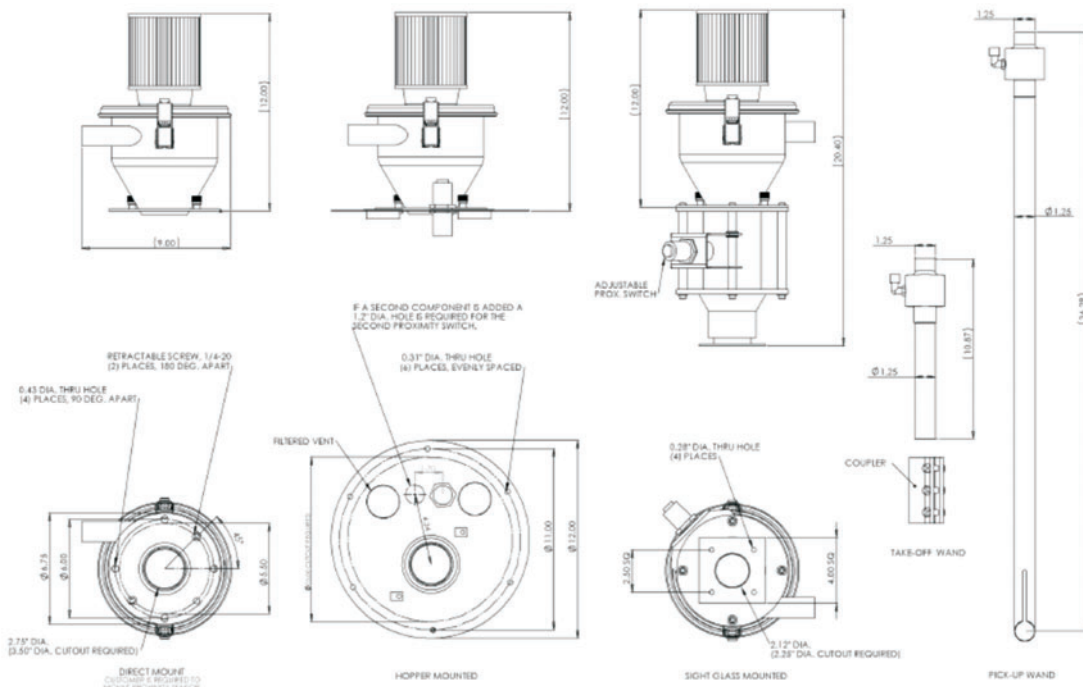

SVL SERIES

SVL-C SPECIFICATIONS - TWO MATERIAL CONVEYING

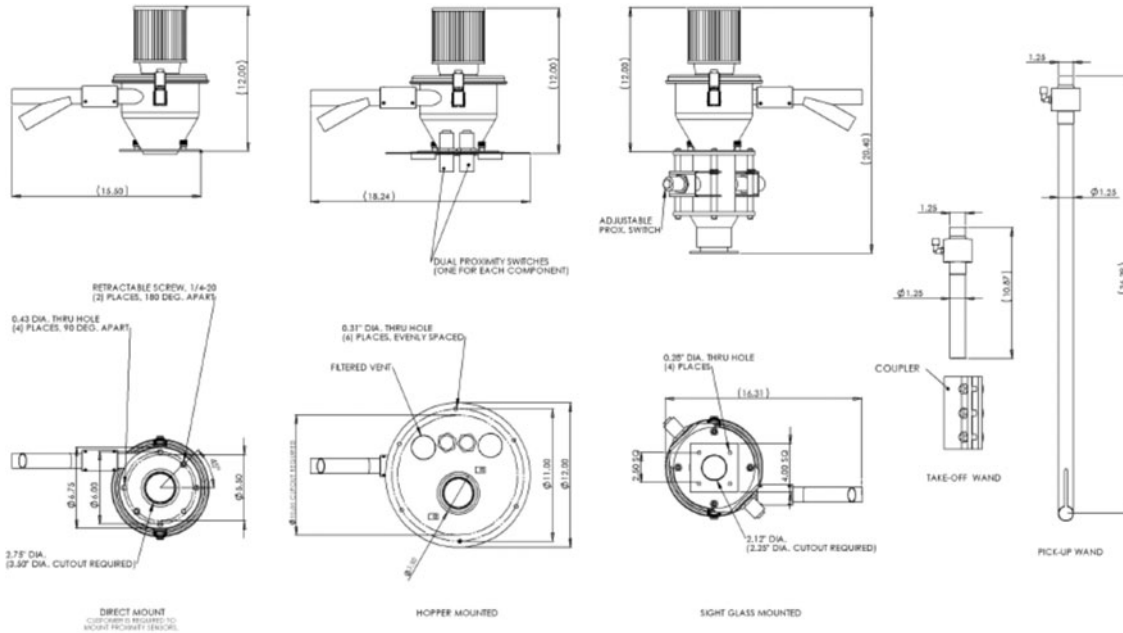

SVL-D SPECIFICATIONS - BARREL/DRUM SYSTEM

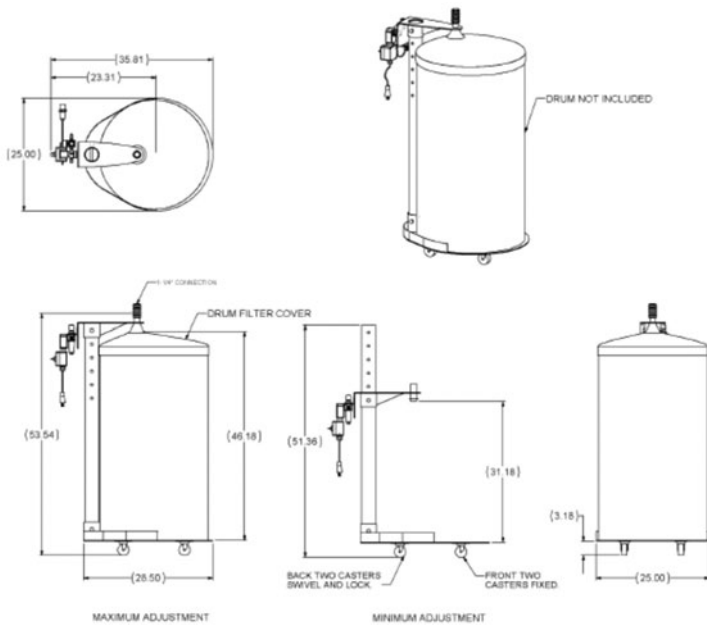

DUST BAG FILTER OPTION

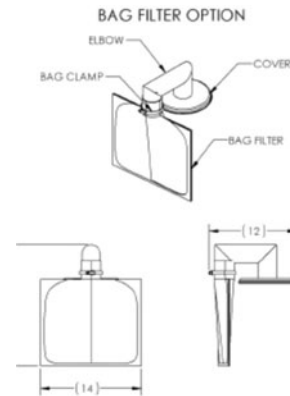

UNIVERSAL TAKE-OFF ADAPTER

