

BULK STORAGE SERIES ACHIEVE A HOMOGENEOUS BLEND IN A SHORT MIX TIME

The Sterling Vertical Batch Blender is a high volume, low cost batch mixer designed to give a homogeneous mix of most dry materials in a short mix time.

It can be charged by auger, blower, vacuum system or bottom feed chute. The Vertical Batch Blender can discharge by auger, vacuum, blower or gravity discharge into a container with the use of extended legs.

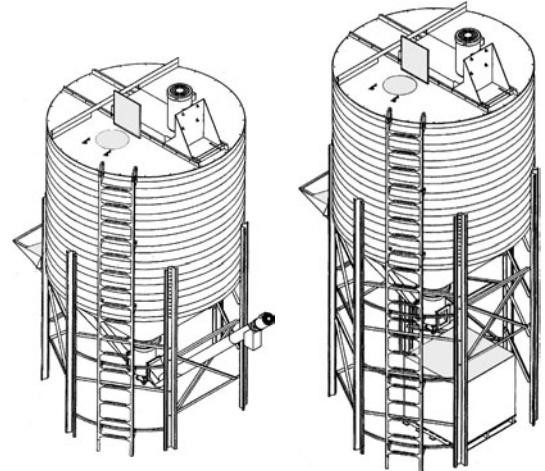

Shown with
auger discharge

Shown with extended
legs for container fill

Features

- Heavy Gauge FDA Approved Galvanized Coated Steel Body
- Plated and Painted Components
- 6", 9" or 12" Heavy Duty Vertical Mixing Auger
- Top Mounted Service Entry
- Bottom Discharge with Slide Gate
- Heavy Duty Industrial Bearing Top and Bottom
- Custom Bottom Load Container Fill Chute
- Heavy Duty TEFC Belt Drive Motors
- Service Ladder
- On Site Installation by Sterling Crews, if Required
- Non-Enclosed Service Ladder

Options

- Custom Extended Legs & Bracing For Container Fill
- Custom Bottom Load Container Fill Chute
- Vacuum Distribution Box Discharge
- Auger Conveyor Discharge (See screw conveyors section)
- Various Slide Gate Discharge Sizes
- Gravity discharge chute with slide gate, hopper mounted, 45°
- View windows
- Material level control indicators: Hi-lo control/alarm box assembly, bell only pilot lights, one red, one green; Hi-lo control/alarm box assembly add on per silo Rotary type level controls; Rotary control mounting flange, corrugated surface; Rotary control mounting flange, flat surface



BULK STORAGE SERIES

SPECIFICATIONS

Usable cu. ft.	Capacity lbs.	Diameter in.	Hopper incline	Standard OAH, in.	Container fill OAH, in.	Auger dia., in.	Motor	Opt. ladder & cage assy.
108	3800	72	60°	148	182	6	230/460V, 3 ph, 5 HP	Consult factory
182	6370	72	60°	179	213	6	230/460V, 3 ph, 5 HP	Consult factory
256	8960	72	60°	211	245	6	230/460V, 3 ph, 5 HP	Consult factory
125	4380	84	45°	136	169	9	230/460V, 3 ph, 5 HP	Custom ladder
226	7910	84	45°	168	202	9	230/460V, 3 ph, 7.5 HP	Consult factory
340	11900	84	45°	200	234	9	230/460V, 3 ph, 7.5 HP	Consult factory
233	8155	108	45°	144	178	9	480V, 3ph, 15 HP	Custom ladder
233	8155	108	45°	144	178	12	240V, 3ph, 15 HP	Custom ladder
402	14070	108	45°	176	210	12	480V, 3ph, 15 HP	Consult factory
402	14070	108	45°	176	210	12	240V, 3ph, 15 HP	Consult factory
572	20020	108	45°	209	241	12	480V, 3ph, 15 HP	Consult factory
572	20020	108	45°	209	241	12	240V, 3ph, 15 HP	Consult factory
739	25865	108	45°	241	273	12	480V, 3ph, 20 HP	Consult factory
739	25865	108	45°	241	273	12	240V, 3ph, 20 HP	Consult factory

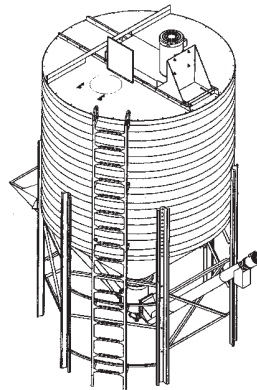
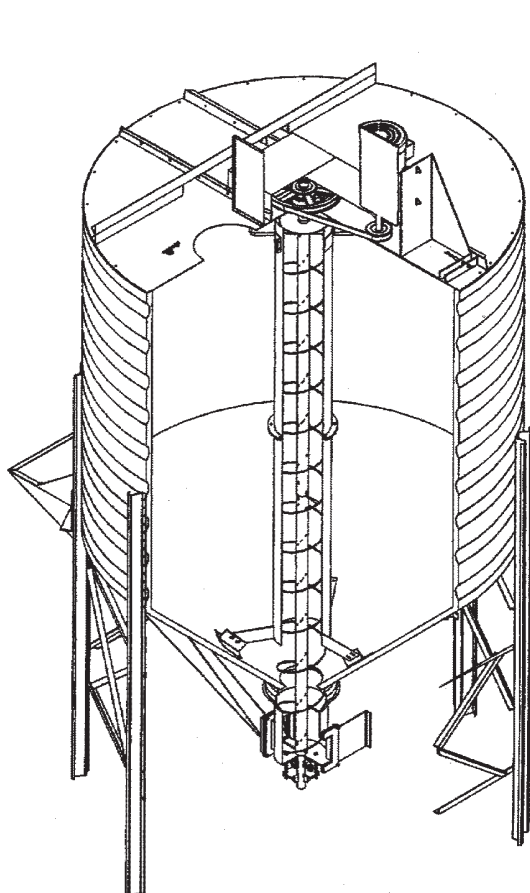

Shown with
auger discharge

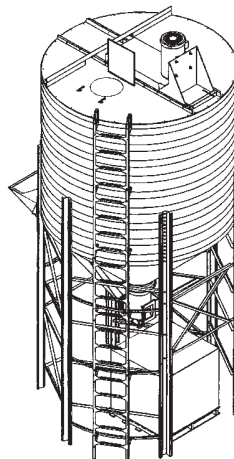

Shown with
extended legs
for container fill

